

SGI® ICE™ XA

The World's Most Powerful
Distributed-Memory Supercomputer

Key Features

191 Pure Compute Teraflops per Rack

Scale from Hundreds to Tens
of Thousands of Nodes

Industry-leading Power & Cooling Efficiency

Optimum Blade, Infiniband Topology,
and Linux O/S Flexibility

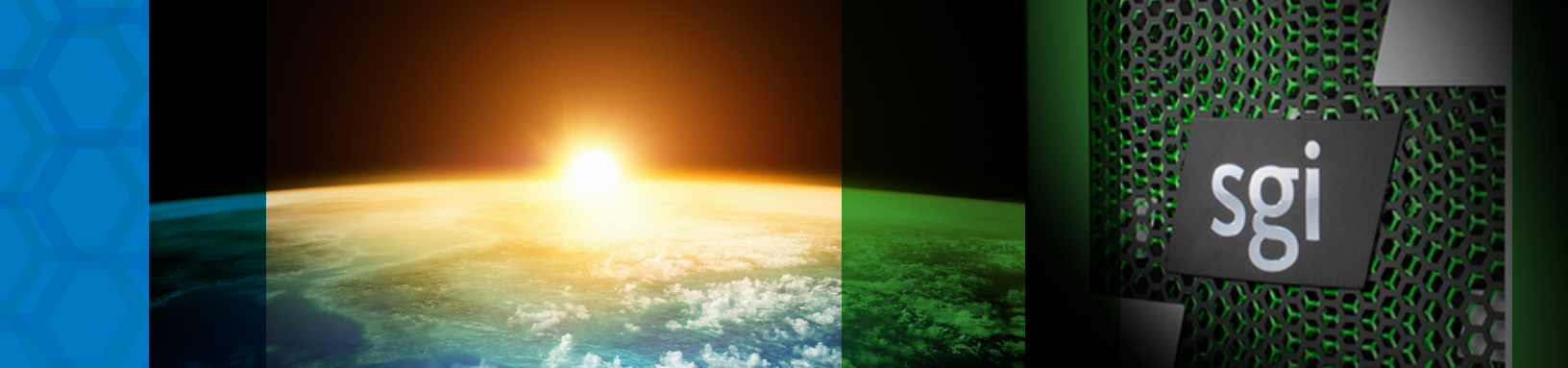

In today's world, High Performance Computing (HPC) is an essential technology for government institutions, universities, and commercial enterprises to solve complex problems in areas ranging from life, earth, and space sciences, to engineering and manufacturing, to national security.

SGI is a global leader in HPC and has been equipping customers with advanced, innovative solutions for over 20 years. SGI ICE is SGI's flagship scale-out platform and when combining speed, scale, and efficiency, provides the most powerful distributed-memory supercomputer in the world.

Key Features

To address the increasing size and volume of HPC workloads, SGI has developed a 6th generation supercomputer, SGI ICE XA. Extending SGI's technology leadership, ICE XA enables scientists, researchers and engineers to achieve and accelerate computational breakthroughs at Petascale and with high return on investment.

- Fully leverage leading commercial applications as well as in-house developed codes using industry-standard, state-of-the art x86, Linux, and integrated InfiniBand technologies
- Enjoy optimum flexibility in processor and accelerator mix, blade and storage configuration, and network topology to meet specific workload requirements

- Reduce operational costs through superior power and cooling efficiency coupled with advanced SGI software for system, health and power management
- Power up and be production-ready in hours to days, not weeks to months
- Grow existing ICE clusters by adding next generation nodes and without user interruption
- Capitalize on SGI's path to Exascale and continuing innovation to solve Terascale and Petascale problems

All ICE XA supercomputers are fully integrated and tested prior to leaving SGI's U.S.-based factory. And for solution design to include Lustre-based storage and intelligent data management, installation, and system support with 24x7 remote monitoring, SGI Professional and Support Service teams are truly the best in the industry.

Speed

SGI ICE XA is designed to run complex HPC workloads at petaflop speed. Compute nodes feature the Intel® Xeon® processor E5-2600 v3 series - SGI's expertise in maximizing Xeon performance is reflected in successive world records to include SPEC MPI2007 benchmarks for the Xeon® E5-2600 v3. Nodes can be further augmented with Intel® Xeon Phi™ Coprocessors or NVIDIA® GPU Accelerators. In addition, SGI Application Engineers have extensive expertise tuning systems to specific workload environments. What matters most is that SGI's performance leadership extends from the laboratory to customer sites, which utilizing pure Intel Xeon®, InfiniBand and Linux technology includes the most powerful commercial supercomputer in the TOP500.

Advanced HPC Software Accelerates Workloads

Behind the blazing speed of SGI ICE XA lies innovative hardware coupled with advanced HPC software.

- **SGI Performance Suite** provides a variety of application acceleration components including specialized libraries, plus a high performance MPI environment.
- **SGI Development Suite** provides an advanced software environment for developing, debugging, and analyzing performance of technical computing applications.
- **SGI Management Suite** is a comprehensive suite of tools for high speed system provisioning, proactive health management, and power resource management at a node level.

Scale

Grow Seamlessly with Extreme Density

SGI ICE XA can provide up to 191 teraflops of pure compute per rack and grow to tens of thousands of nodes with minimal increase in system overhead.

Blade, Infiniband Topology, and OS Flexibility

The highly differentiated architecture of SGI ICE XA provides optimum flexibility in system configuration.

- **Compute Blade:** Choose from two blade types. The IP-125 is a quad node compute blade with 2-sockets per node (total 8 sockets), delivering maximum Intel Xeon® processor capabilities. The IP-139 is a dual node compute blade with 2-sockets per node (total 4 sockets), coupled with HDD/SSD drives or PCI-e slots to jointly increase processing and I/O capabilities. Both blades can also utilize an innovative cold sink technology to provide high node density at proper heat levels.

- **Blade Enclosure:** 10.5U blade enclosures provide power, cooling, system control, and network fabric for up to 9 compute blades via an integrated midplane. ICE XA can be expanded by simply adding enclosures, with up to four blade enclosures in a single 42U high rack. The enclosure is also designed to support future blade technologies.
- **InfiniBand Topology:** SGI ICE XA utilizes industry standard InfiniBand networking – preferred by half of the Top500 sites and growing – with complete flexibility in topology. Choose from All-to-All, Fat Tree, Hypercube, or Enhanced Hypercube fabrics with single or dual plane (separate MPI and IB traffic) to best meet performance, system size, budget, and application needs.
- **Operating system:** ICE XA runs standard SUSE® Linux Enterprise Server, Red Hat® Enterprise Linux®, or CentOS. Different Linux operating systems can be provisioned on different nodes, thereby allowing a broad range of Linux-based HPC applications to run simultaneously. SGI is one of the largest contributors to the Linux community and brings deep expertise deploying and optimizing Linux systems.

Scale Out Live with Next-gen Technologies

SGI's ICE platform features "Live Integration" whereby systems can be expanded using next generation processors, accelerators, networking, without interrupting users. This highly valuable capability has been demonstrated best at NASA's Ames Research Center, whereby twenty live platform upgrades, spanning five generations of ICE innovation, has saved them tens of millions of user computational hours of productivity during downtime that is typically associated with generational upgrades.

Efficiency

Cutting-Edge Power and Cooling

Energy efficiency and green computing is an increasingly important requirement for supercomputers, and for which SGI has been a principal innovator and champion for many years to include:

- Industry-leading Megaflops per Watt for x86 platforms
- Top 4 out of 5 Most Efficient Supercomputers in Top500

ICE XA extends SGI's leadership in power and cooling efficiency with:

- **New E-Cell design:** Featuring 2nd generation SGI Cell technology, ICE XA systems are deployed as E-Cells. Two compute E-racks and a unified cooling rack are placed in a sealed E-Cell, with multiple cells connected to form large systems. A cooling rack within the cell draws hot air via an air-to-water heat exchanger and recirculates it to cool the compute racks. This "Closed-Loop Airflow" ensures no air from within the cell is mixed with data center air. In addition, the cell is always water-cooled.
- **Warm water cooling:** The E-Cell utilizes facility-supplied water for cooling and will not add any heat to the data center if the water temperature is within 45-90 degrees Fahrenheit (7-32C). This high 90F "Room Neutral" water temperature is often 30% or more efficient than industry competitors and can save millions in cooling costs. An air-to-water heat exchanger is provided with all E-Cells, and a water-to-water heat exchanger is deployed when cold sinks are utilized in the compute and switch blades.
- **Power supply efficiency:** Each blade enclosure in an E-rack is configured with up to 9 power supplies and supports N+1 power redundancy. The number of loaded power supplies can also be controlled so as to not draw unnecessary power and waste energy. The highly efficient design enables ICE XA to achieve a 94% power distribution at 50% load using 80 PLUS Platinum.

Path to Exascale

Regarded as the next frontier in high performance computing, SGI is on a path to deliver supercomputers capable of an exaflop by 2020. Managing power consumption at a job level, utilizing higher facility water temperatures and full liquid immersion, and bringing high-speed SSD storage close to processors to accelerate I/O and reduce power consumption are among many areas of continuing innovation. While these ICE platforms will be built for only the largest of HPC environments, SGI's Exascale technology will extend broadly to solving compute problems at Tera- and Petascale.

SGI ICE XA E-Cell

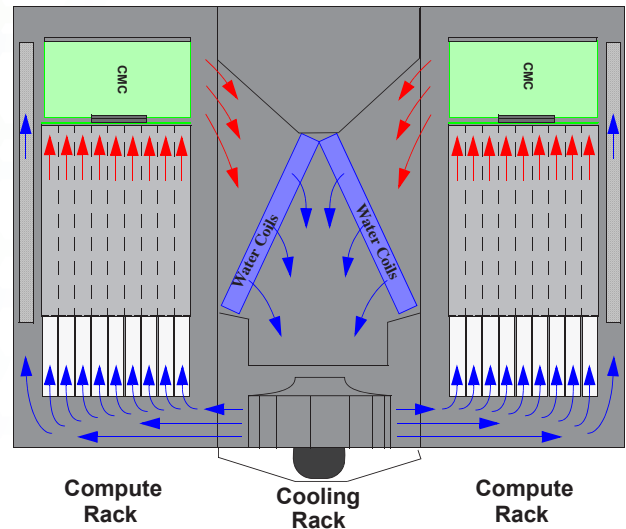

Closed Loop airflow insulates E-Cell from data center environment

Compute Blades	IP-125CS	IP-139CS
Processors	Intel® Xeon® Processor E5-2600 v3 Series	Intel® Xeon® Processor E5-2600 v3 Series
Compute Nodes/ Blade	Four 2-socket CPU nodes	Two 2-socket CPU nodes
Memory/ Node	64-512GB/ node; 8 DDR4 DIMM slots (4 per CPU socket)	64-512GB/ node; 8 DDR4 DIMM slots (4 per CPU socket)
Memory Capacities	8, 16, 32 and 64GB 2133 MT/s ECC Registered DIMMs	8, 16, 32 and 64GB 2133 MT/s ECC Registered DIMMs
Coprocessor/ Accelerators (optional)	Not Applicable	<ul style="list-style-type: none"> Intel® Xeon Phi™ 7120 Coprocessor NVIDIA® Tesla® K40 GPU Accelerator
I/O (optional)	Up to 8 Low Profile IO Cards (Infiniband, Intel® True Scale, Fibre Channel, Ethernet (1,10 & 40Gb))	Up to 4 Low Profile IO Cards (Infiniband, Intel® True Scale, Fibre Channel, Ethernet (1,10 & 40Gb))
Storage (optional)	Up to eight 2.5" SATA drives (HDD or SSD) per blade (2 per logical node)	Up to eight 2.5" SATA drives (HDD or SSD) per blade (4 per logical node)
Mezzanine Card	Single or Dual Port FDR Connect-IB, EDR*, Intel® Omni-Path*	Single or Dual Port FDR Connect-IB, EDR*, Intel® Omni-Path*
Cooling	SGI ColdSinks	SGI ColdSinks
Topologies Options	Single or dual plane all to all, fat tree, hypercube and enhanced hypercube	Single or dual plane all to all, fat tree, hypercube and enhanced hypercube

Blade Enclosure	Standard	Premium
Integrated Switch	Single 36 port FDR IB ASIC with 18 ports external	Dual 36 port FDR IB ASIC with 36 ports external
Administrative Network	Dedicated GigE network (redundancy optional), chassis management controller	

Storage	InfiniteStorage InfiniBand Solutions
	<ul style="list-style-type: none"> High performance shared file systems IP over IB Native IB block level access Native IB SAN supported with CXFS

Racks	D-Rack (For I/O & Support Nodes)	E-Rack (For Compute Blades)
Specifications	83.2"H x 24.0"W x 49.5"D for air cooled rack. Water cooled rack is 54.8"D. 42U w/ 19" standard EIA mounting rails. Can optionally be extended to 48U	89.6"H x 24.0"W x 48.0"D. Room neutral up to 32°C datacenter supply water
Blade Enclosure Support	n/a- used for I/O & support nodes	Up to four blade enclosures (36 logical nodes each)
Power	Single and three-phase PDUs	Up to 8+1 redundant 3000W power supplies per blade enclosure
Cooling	Open looped airflow or water (optional)	closed loop airflow/ water

System Management	HSM	Tier 1: System Administration Controller	Tier 2: Rack Leader Controller (RLC)	Tier 3: Chassis Management Controller	Tier 4: Baseboard Management Controller
	<ul style="list-style-type: none"> One per ICE system Provisions out software to RLC Pulls aggregated cluster management data from RLC 	<ul style="list-style-type: none"> One per eight blade enclosures (two E-Racks) Holds blade boot images Runs fabric management software Aggregates cluster management data for rack 	<ul style="list-style-type: none"> One per enclosure Controls master power to all compute nodes Monitors power and blade enclosure environment 	<ul style="list-style-type: none"> One per compute node Controls board-level hardware Monitors compute node environment 	
Service Node Options	<ul style="list-style-type: none"> Login Node Gateway Node Batch Node Storage Node OSS Node MDS Node* 	<ul style="list-style-type: none"> Service nodes can be optionally configured with: <ul style="list-style-type: none"> GPUs such as NVIDIA® Tesla™ K10,K20, K40 & K80 Coprocessors such as Intel® Xeon Phi™ 5110, 5120 & 7120 I/O connectivity (various) Hard Disk Drives (SAS and/or SATA) I/O connectivity (various) 			

System Software	Operating Systems	Cluster Solution Stack
	<ul style="list-style-type: none"> SUSE® Linux Enterprise Server 11, 12 Red Hat® Enterprise Linux 6, 7 	<ul style="list-style-type: none"> SGI Management Suite: System Management software consisting of SGI Foundation Software and SGI Management Center SGI Performance Suite optimized application performance package consisting of SGI Accelerate, SGI MPI, SGI REACT Altair® PBS Professional™: Workload management tool with support for SGI Power Management

Software Development	Programming Languages and Debuggers	Libraries
	<ul style="list-style-type: none"> C & C++: Intel® C++ Compiler, PGI® PGC++®, GNU GCC Debuggers: Intel® Debugger included with Intel® compilers, PGI® PGDBG®, Rogue Wave Software® TotalView® Team, Allinea DDT, GNU GDB Fortran: Intel® Fortran Compilers, PGI® PGFORTRAN®, GNU GCC Performance Analysis: Intel® VTune Amplifier XE, Intel® Trace Analyzer & Collector, PGI® PGPROF® 	<ul style="list-style-type: none"> SGI MPI OpenMP included with Intel® compilers Intel® Math Kernel Library Intel® Parallel Building Blocks Intel® Integrated Performance Primitives Intel® MPI Library

About SGI

SGI is a global leader in high performance solutions for compute, data analytics and data management that enable customers to accelerate time to discovery, innovation, and profitability. Visit sgi.com for more information.

*Contact SGI Sales for release timing.

Global Sales and Support: sgi.com/global

©2015 Silicon Graphics International Corp. All rights reserved. SGI, the SGI logo and ICE XA are registered trademarks or trademarks of Silicon Graphics International Corp. or its subsidiaries in the United States and/or other countries. Intel, Xeon and the Intel Xeon logo are registered trademarks of Intel Corporation. Lustre is a registered trademark of Xyratex Technology, Ltd. in the United States. Other names may be claimed as property of others. All other trademarks are property of their respective holders. 05112014 4529 17062015

For More Information

For more information about how SGI ICE XA can benefit your organization, visit www.sgi.com or call 1-800-800-7441.

